



goslyn™ MODEL GOS20 4 GPM Grease Removal Device



Model: GOS20
Capacity: 4 Gallons / Minute

GOS20 – Standard Features:

- Heavy duty 2.5 mm, 304 Stainless Steel exterior construction
- Neoprene seals on base of unit
- Fixed rate flow restrictor included (4 gal. / minute)
- Immersion heater (UL listed) to keep effluent warm during idle periods
- Self-closing drain valve included
- Strainer basket to prevent solid debris from entering the drain pipes
- Easy access hinged lid compartments
- Two oil collection cassettes included
- No moving parts
- Manufactured to ASME A112.14.3 and ASME A112.14.4 standards
- Five Year Limited Warranty



Short Form Specification

Shall be a Goslyn Model: GOS20 grease removal device / immiscible liquid separator which continuously operates under hydro static pressure with no moving parts. Is made of 2.5 mm, 304 stainless steel and comes standard with an immersion heater and two (2) oil recovery cassettes. It has a capacity of 4 gallons per minute and is UL, NSF, IAPMO / UPC approved.

“The easiest & most effective GRD to operate & maintain!”



Goslyn LP
1904 University Business Dr
Suite 310
McKinney TX 75071

Phone: 888-648-5040
Fax: 214-618-3765
www.goslyn.com



goslyn™ MODEL GOS20 4 GPM Grease Removal Device



Model:	GOS20
Shipping Dimensions	15.5" X 20.5" X 15.52" 39.4 cm X 52.1 cm X 39.4cm
Shipping Weight	45 lbs. / 20.4 Kg
Required Clearances	<ul style="list-style-type: none"> • Headroom needed above strainer basket: 12" • 1.5" inlet • 1.5" outlet • Access to front Oil Cassette • Access to hinged lid for Oil Valve
Approval Agencies:	UL; NSF; IAPMO / UPC; CSA
Electrical Requirements:	110 Volt, 1000 watts, 9 Amps within 5' of unit

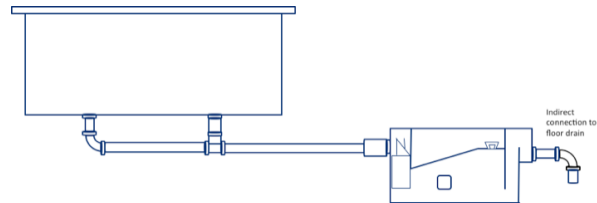

The Goslyn Outlet may **discharge either indirectly** (e.g., into a floor sink, as shown in the above schematic) **or directly** to a drainpipe.

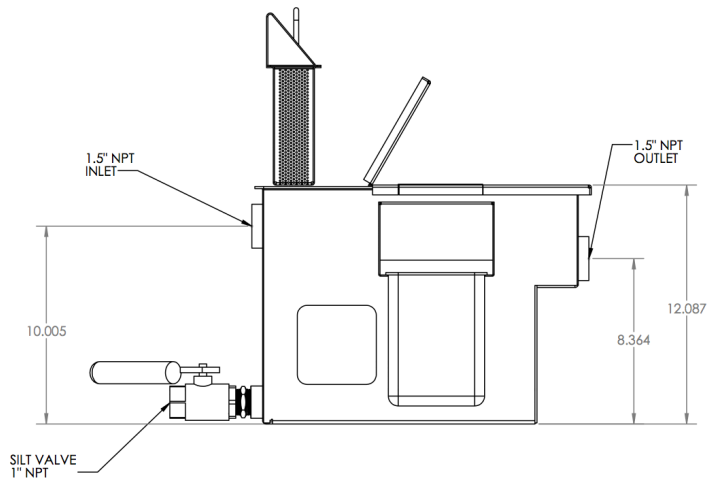
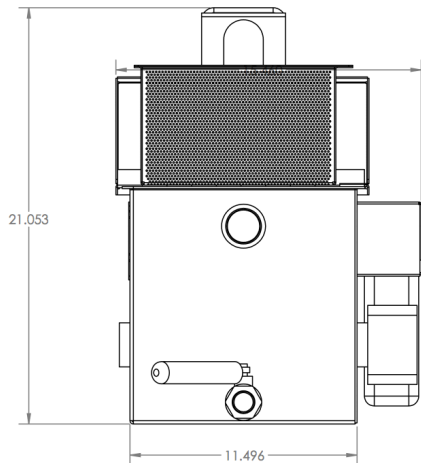
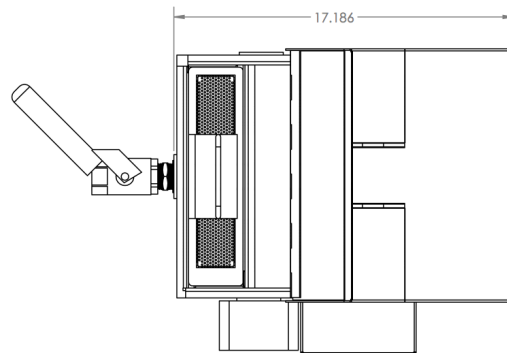

"The easiest & most effective GRD to operate & maintain!"



Goslyn LP
1904 University Business Dr.
Suite #310
McKinney, Texas, U.S.A. 75071

Phone: 888-648-5040
Fax: 214-618-3765
www.goslyn.com